

Best Availability

Safety valves and
upstream bursting
discs in combination



CATALOG

LESER

The-Safety-Valve.com

LESER Safety Valves for every industrial application



Best Availability



High Performance

Safety valves and bursting discs in combination



API



Clean Service



Critical Service



Modulate Action



Compact Performance

Overview	Chapter/Page	Chapter/Page
General Information		
General Information	00/01	
Applications, General design features	00/02	
	Chapter/Page	
Safety valves and bursting discs in combination		
Components	01/01	
Functions and technical design	01/02	
Components – BT-KUB bursting disc	01/03	
Components – Space monitoring device	01/04	
Codes and standards	01/05	
Installation and maintenance	01/06	
Material characteristics	01/07	
Signal bursting disc	01/08	
		Chapter/Page
Safety valves and bursting discs in combination		
How to order – Safety valves and bursting discs in combination		02/01
IG-KUB two-piece holder		02/03
BT-KUB bursting disc		02/04
Space monitoring device		02/05
Combination		02/06

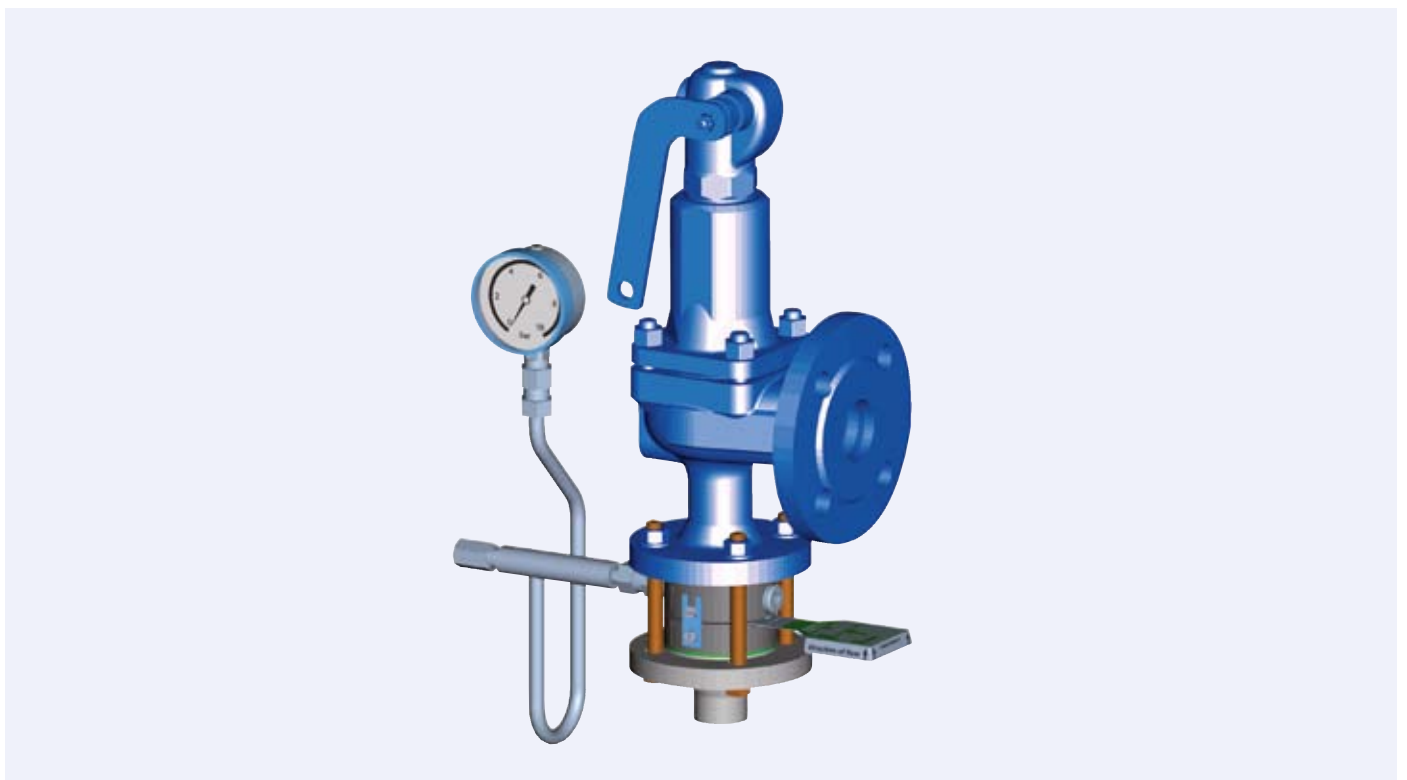

Safety valve and bursting disc in combination

LESER – safety valves and bursting discs in combination

LESER safety valves and bursting discs in combination stand for:

- ✓ Fulfilment of highest tightness requirements
- ✓ Combining the advantages of safety valves and bursting discs in TÜV-examined combinations
- ✓ Monitored operation after rupture of the bursting disc

Why safety valves and bursting discs in combination?

The combination of bursting disc and safety valve is the solution for the following applications:

- to protect the safety valve against corrosion or coating build-up
- to protect against operating conditions, which could impair the functionality of the safety valve
- to ensure the process with the best possible tightness
- to prevent a complete loss of medium after the rupture of the bursting disc
- to prevent an uncontrolled shut-down of a system after the rupture of the bursting disc
- to achieve cost advantages for aggressive mediums

LESER safety valves and bursting discs in combination

- are characterised by longstanding proof in service.
- are absolutely tight and meet the highest tightness requirements (such as TA Luft).
- extend the maintenance intervals. This results in the increased lifespan of the safety valve and therefore increases the system productivity.
- facilitate a function test of the safety valve during operation and thus reduce system stand stills.
- avoid high safety valve costs and long delivery periods for applications which require special materials.
- prevent excessive heat to the safety valve during high-temperature applications. This makes the use of highly heat-resistant materials unnecessary.
- are reliable due to easy installation and handling.
- have proven their reliability during the process of obtaining VdTÜV certification of the safety valves.

Safety valves and bursting discs in combination from LESER facilitate coordinated planning, sizing and delivery from a single source.



Applications

LESER safety valves and bursting discs in combination are used for the following applications:

- for mediums which have a tendency to be sticky, such as
 - marzipan
 - bitumen
- to protect the safety valve against contamination, such as
 - waste water
 - coal slurry
- for highest tightness requirements, such as
 - toxic and highly corrosive mediums (such as chlorine)
 - expensive mediums (such as pharmaceutical products)
 - vacuum applications
- when using special materials for cost advantages and shorter delivery times, for example,
 - the safety valve of stainless steel can be protected by the bursting disc made of Hastelloy®

Design features

- Valve sizes from DN 25 to DN 400, 1" to 16"
- Nominal pressure ratings of PN 16 to PN 160, CL 150 to CL900
- Opening pressures of 0.6 bar to 200 bar / 8.7 psig to 2900 psig
- Bursting disc materials and temperature ranges:

	Material	1.4404		Hastelloy®		Inconel®	
Temperature ranges	Min. [°C/°F]	-30	-22	-30	-22	-22	-30
Rembe® KUB bursting discs	Max. [°C/°F]	320	608	420	788	550	1022
	Material	Tantalum		Titanium		Monel®	
Temperature ranges	Min. [°C/°F]	-22	-30	-30	-22	-30	-22
Rembe® KUB bursting discs	Max. [°C/°F]	230	446	150	302	400	752

- TA Luft conformal process validation offers the best possible tightness.
- High activation precision, for defined pressure releases.
- Operating pressures of up to 98% of the minimum set pressure of the bursting disc are possible, and this provides an optimal utilisation of the system.
- Performance, discharge number and opening characteristic of the safety valve are not effected.
- Compliance to the 3% criterion – the bursting disc does not have to be considered in the sizing.

LESER – safety valves and bursting discs in combination

Worldwide Use

The LESER safety valves and bursting discs in combination are tested and approved in accordance with VdTÜV. Application of the combination is done according to

- EN ISO 4126-3
- AD 2000-Merkblatt A1
- ASME Sec. VIII Div. 1

LESER safety valves and bursting discs are accepted individually in accordance with numerous rules and regulations. This ensures the worldwide applicability of the combinations. Examples of this are:

Country	Safety valve approvals	Bursting disc approvals
Europe	<ul style="list-style-type: none"> – CE marking as per Pressure Equipment Directives 97/23/EC and – EN ISO 4126-1 	<ul style="list-style-type: none"> – CE marking as per Pressure Equipment Directives 97/23/EC and – EN ISO 4126-2
USA	<ul style="list-style-type: none"> – UV stamp as per ASME Section VIII Division 1 – National Board certified capacities 	<ul style="list-style-type: none"> – UD stamp as per ASME Section VIII Division 1 – National Board certified capacities
Germany	<ul style="list-style-type: none"> – VdTÜV approval as per AD 2000-Merkblatt A2 – EN ISO 4126-1 – TÜV SV 100 	<ul style="list-style-type: none"> – VdTÜV approval as per AD 2000-Merkblatt A2 – EN ISO 4126-2/ -6



Safety valves and bursting discs in combination

Components

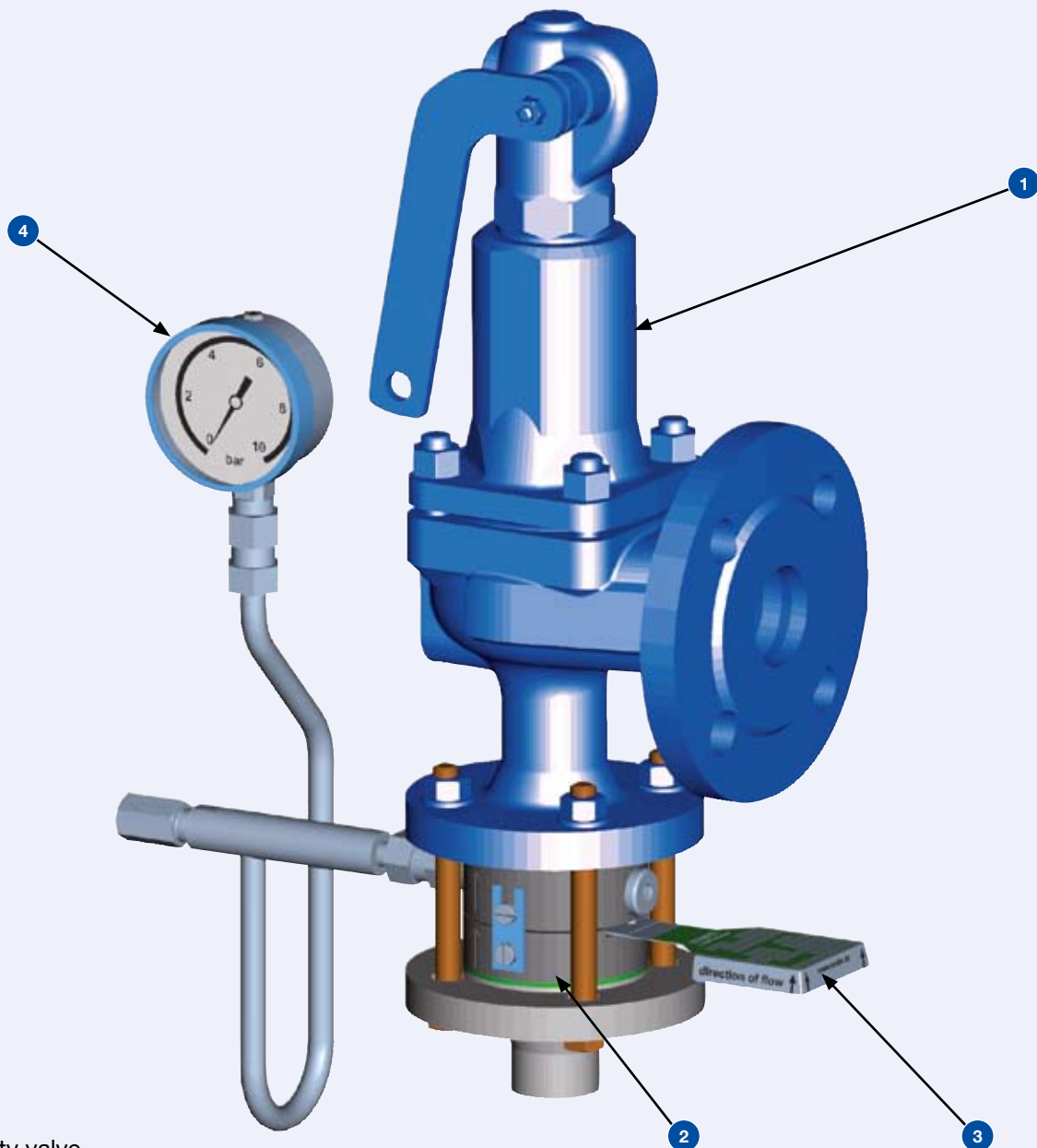

- 1 Safety valve
- 2 Bursting disc holder
- 3 Bursting disc
- 4 Space monitoring device and pressure gauge

Functions and technical design

Safety valve ①

Function

"Valve which automatically, without the assistance of any energy other than that of the fluid concerned, discharges a quantity of the fluid so as to prevent a predetermined safe pressure being exceeded, and which is designed to re-close and prevent further flow of fluid after normal pressure conditions of service have been restored."

(EN ISO 4126-1, par: 3.1)

Technical design

LESER delivers spring-loaded and pilot-operated safety valves for every industrial application with steams, gasses or liquids. Details regarding LESER safety valves can be found in the product catalogues or in the internet at www.leser.com.

Bursting disc holder ②

Function

The bursting disc holder is the component of a bursting disc device that holds the bursting disc in its position and ensures outward tightness. It is clamped between the flanges of the inlet line and the safety valve, and serves the installation on site. The space monitoring device is connected to the bursting disc holder.

Technical design

As a bursting disc holder, LESER uses the holder "IG-KUB-Zweitteilhalter" (two-piece holder) by REMBE® GmbH SAFETY+CONTROL, which is intended for the reverse buckling-pin bursting disc BT-KUB and consists of inlet and outlet components. After rupture of the bursting disc, it has to be replaced. The holder can generally be used again.

The sealing of the bursting disc is done metallicity within the holder by a special sealing edge. The space between the bursting disc and the safety valve is monitored for accumulated pressure. For this purpose, the outlet component is designed with a threaded hole laterally, into which the space monitoring device is screwed.

Due to the various connection types on the safety valve, LESER offers the IG-KUB-two-piece holder in two differing designs:

- Design S: Two-piece holder for safety valves with semi nozzle
- Design HS: Two-piece holder for safety valves with full nozzle

Due to the design of the outlet component, the release of the total orifice area is always ensured.

Bursting disc ③

Function

The bursting disc is the pressure bearing and pressure reacting component of a bursting disc device. It is a non-reclosing relief device.

Technical design

LESER uses the BT-KUB bursting disc (KUB = reverse buckling-pin bursting disc) by REMBE® GmbH SAFETY+CONTROL. This refers to a pressure bearing reverse bursting disc, or in other words, the bursting disc is convexly arched and has a two-layer construction. The rupture of the bursting disc is independent of the tightening torque of the flange screws. It is characterized by Euler's buckling-pin principle. By using this pressure-based method and with the help of CNC laser processing technology, very low bursting tolerances can be realised. The standard tolerance is -0 / +10% in terms of set pressure. Special tolerances are possible. In this case, please specify your required tolerances when placing your order.

Space monitoring device and pressure gauge ④

Function

For safety valves and bursting discs in combination, a space monitoring device must be provided according to codes and standards. It has the function of

1. showing if the bursting disc has ruptured.
2. ensuring the ventilation of the space between the area of the bursting disc and the safety valve seat. Without ventilation, back pressure could build up, which would affect the bursting pressure.

Technical design

The technical design can be found in chapter "Space monitoring device" on page 01/04.

BT-KUB bursting disc components

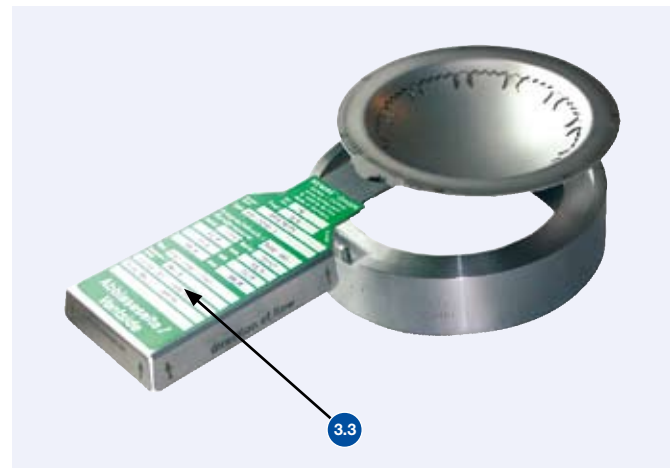
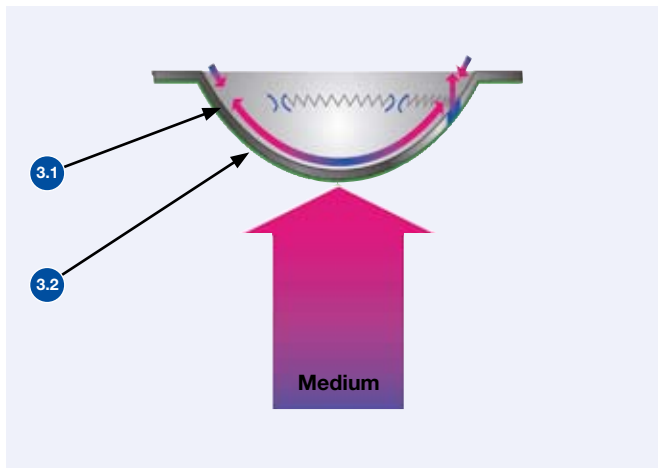

The bursting disc **3** consists of:

- 3.1** Bursting element
- 3.2** Sealing membrane
- 3.3** Bursting disc flag

Bursting element **3.1**

Function

The bursting element, also known as buckling-pin element, for the BT-KUB bursting disc, is the pressure-bearing part of the bursting disc. It has no contact to the medium, as it is sealed by a sealing membrane (3.2). When the set pressure is reached, the buckling-pins break away. The bursting element rips open, without fragmenting, and opens up the entire orifice. The sealing membrane is fully opened by means of an integrated sprocket.

Technical design

The thickness of the bursting elements as well as the number and design of the buckling-pins are pressure-dependent. The bursting element design is adapted to operating conditions. The material is partially perforated by using a laser. The remaining bars represent the buckling pin elements.

Sealing membrane **3.2**

Function

The sealing membrane is the process-oriented component. It ensures the sealing and in addition serves as corrosion protection for the bursting element.

Technical design

The sealing membrane is a metallic film with defined material attributes. The material of the sealing membrane is adapted to the respective operating conditions.

Bursting disc flag **3.3**

Function

The bursting disc flag, also known as name plate, is located outside the process and has to be provided and marked according to the leading codes and standards. The following technical information are listed on the bursting disc flag:

- Manufacturer
- Type mark
- number of production series
- free flow cross-section
- material No. or material designation
- maximum response pressure at room temperature and operating temperature if applicable
- minimum response pressure at room temperature and operating temperature if applicable
- relevant clamping device, e. g. type mark, DIN No.,
- blow-off side

Technical design

The bursting disc flag is permanently attached to the bursting element.

Space monitoring device components

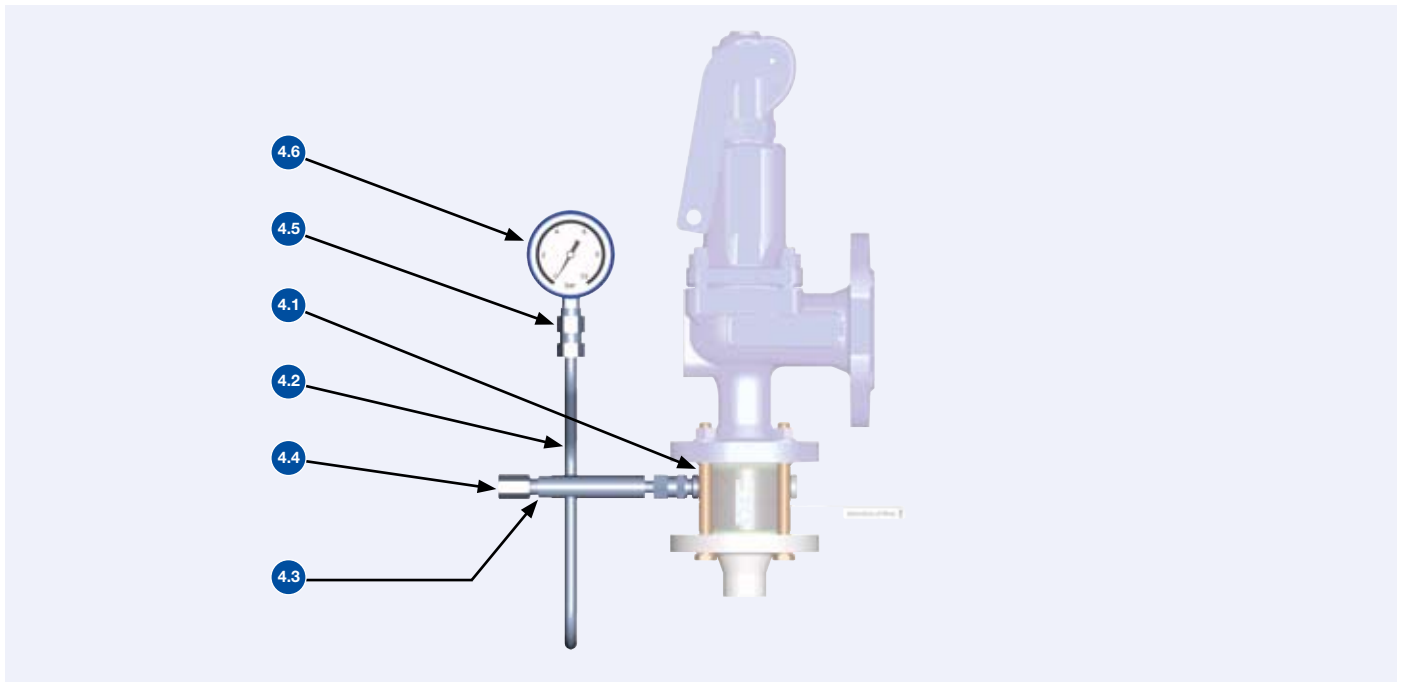

Space monitoring device 4

The space monitoring device is designed as a syphon and consists of:

- 4.1 Pipe fitting
- 4.2 Syphon
- 4.3 Sealing ring
- 4.4 Excess overflow valve
- 4.5 Pressure gauge connection incl. sealing ring
- 4.6 Pressure gauge

Technical design

With a pipe fitting (also known as a double nipple), the syphon is mounted with the sealing ring and the excess overflow valve (also known as expansion valve) in the discharge side of the two-piece holder. It must be ensured that the arrow on the excess overflow valve is pointing towards the free outlet side, in order to guarantee the function of the ball enclosed within.

Caution:

The excess overflow valve should never be closed at the outlet.

The pressure gauge connection (incl. sealing ring) is mounted on the syphon. The syphon guarantees that accumulating condensate cannot impair the function of the pressure gauge.

Pressure gauge 4.6

Technical design

LESER offers pressure gauges in various designs:

Standard pressure gauge: Ø 63, G $\frac{1}{4}$, Device class 1, IP 65

Trailing pointer gauge: Ø 100, G $\frac{1}{2}$, Device class 1, IP 65

Contact gauge: Ø 100, G $\frac{1}{2}$, Device class 1, IP 65

Codes and standards for safety valves and bursting discs in combination

AD 2000-Merkblatt A1, par.: 5.4.1.1

Bursting safety devices can be arranged either before or after the safety valve. A bursting device – safety valve – bursting device arrangement is also possible.

EN ISO 4126-3, par.: 3.1

A combination device comprises a bursting disc and separated from the safety valve inlet by no more than a length equivalent to five times the nominal size of the inlet piping.

ASME Section VIII Division 1 par.: UG-127 3b

A rupture disc device may be installed between a pressure relief valve and a vessel.

API 520 Part 2, par.: 4.6

A rupture disc device may be installed between a pressure relief valve and a vessel or on the downstream side of a pressure relief valve.

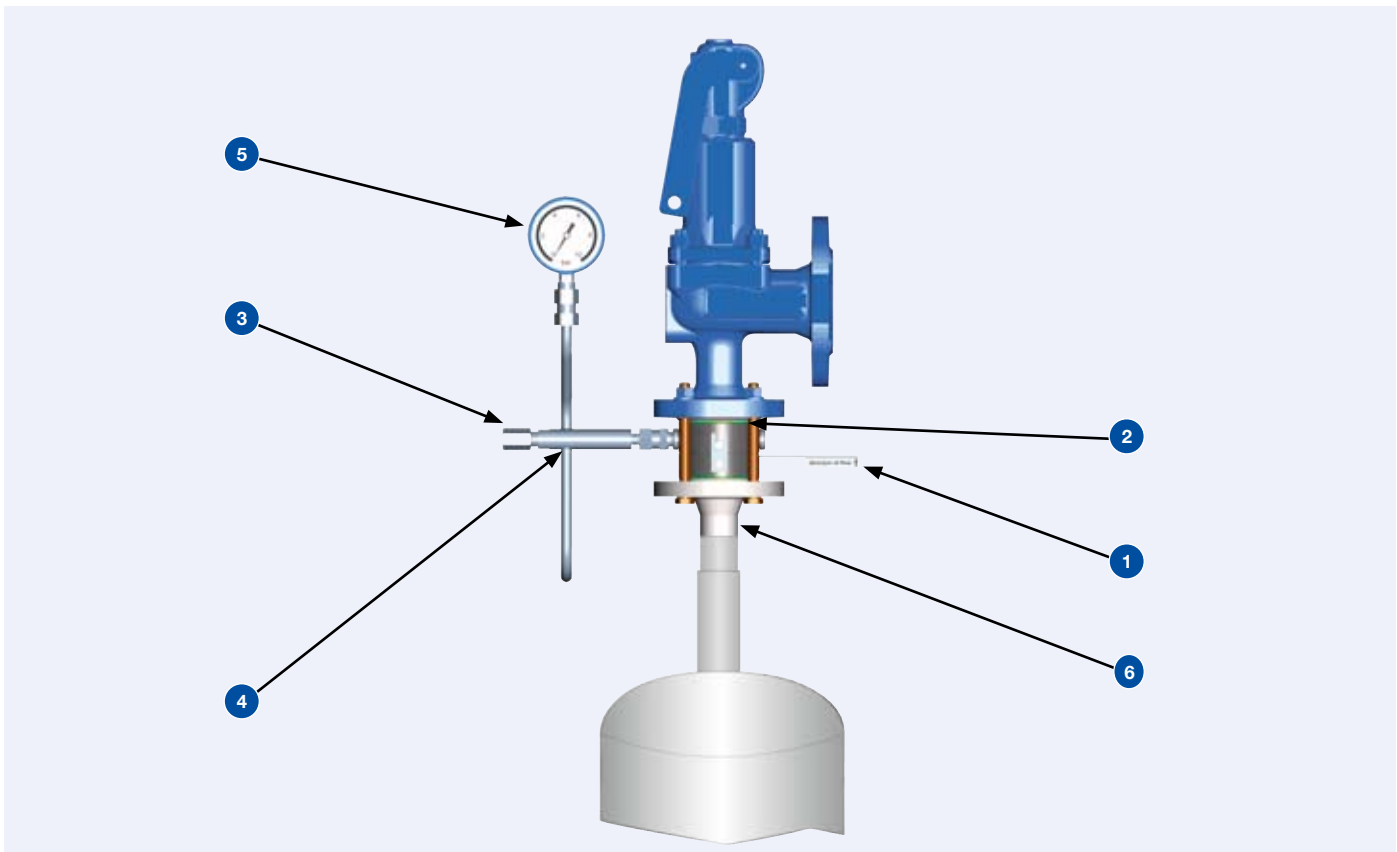

Requirements to safety valves and bursting discs in combination

- 1 For bursting safety devices in front of safety valves, non-fragmenting bursting elements must be used.
- 2 The space or volume between the bursting safety device and safety valve shall be chosen such that a correct opening of the bursting element is ensured.
- 3 The space between both safety devices must be ventilated, because the potential development of back pressure would change the set pressure of the bursting safety device respectively the safety valve.
- 4 It must be possible to drain the accumulating condensate between the bursting disc and the safety valve.
- 5 A device must be provided, that detects a leakage in the safety device as well as an rupture of the bursting element.
- 6 Inlet lines and bursting safety devices before safety valves shall be designed such that the pressure loss in the feed line at the maximum drawn off mass flow does not exceed 3 % of the pressure difference between the maximum allowable pressure and the external back pressure.

Sizing of the combination

Through testing, the BT-KUB bursting discs by REMBE® GmbH SAFETY+CONTROL are optimally adapted to LESER safety valves. No flow loss occurs due to a ruptured bursting disc in the inlet line to the safety valve, which means that the combination can be designed as an individual safety valve. This has been tested and certified by TÜV within the scope of safety valve approval.

However, at sizing of the combination according to ASME Sec. VIII Div. 1, it must still be ensured that a correction factor of 0.9 in terms of performance of the individual safety valve be included in the calculation. LESER recommends that the bursting pressure of the bursting disc should be arranged to be equal to the set pressure of the safety valve.

Installing the combination

A locating pin guarantees that the bursting disc will be pre-mounted in the proper position. The positioning of the bursting disc (BT-KUB pre-mounted in IG-KUB two-piece holder) within the flange connection is done by flange screws. Arrows on the holder mark the flow direction.

The user must provide appropriate seals for the sealing between the holder and the connection flanges. The IG-KUB two-piece holder is available for flanges based on EN or ASME. Sealing surfaces and dimensions of the holder can be adapted to all established standards upon request.

Opening of the combination

In the case of opening, the bursting disc opens fragmentation-free and releases the total orifice area. It is guaranteed that the total discharge capacity is available. After opening, the system can continue to operate in spite of the ruptured bursting disc, because the safety valve closes again and takes over the safety function. Depending upon the application, the bursting disc should be replaced as soon as possible.

Replacement bursting discs

Bursting discs are individually produced for every set pressure, wherefore LESER recommends that the operator orders several bursting discs to have in storage with the first order.

Maintenance

KUB bursting discs are basically maintenance-free. However, to avoid unintentional bursting respectively leakage as a result of damage and/or wear and tear, corrosion, etc., a visual inspection should be conducted at least once per year. Maintenance intervals for safety valves can be extended by upstream bursting discs; this increases the lifetime of the safety valves.

The LESER safety valve in combination with the KUB *V-Series* bursting disc has the additional advantage that the safety valve can be subjected to a set pressure test without being dismantled on installed position. The pressurising is conducted through space monitoring device. The pressure build-up behind the bursting disc may have up to 1.35 times the bursting pressure. Functionality and idle time of the bursting disc remain unchanged, even with frequent function testing of the safety valve.

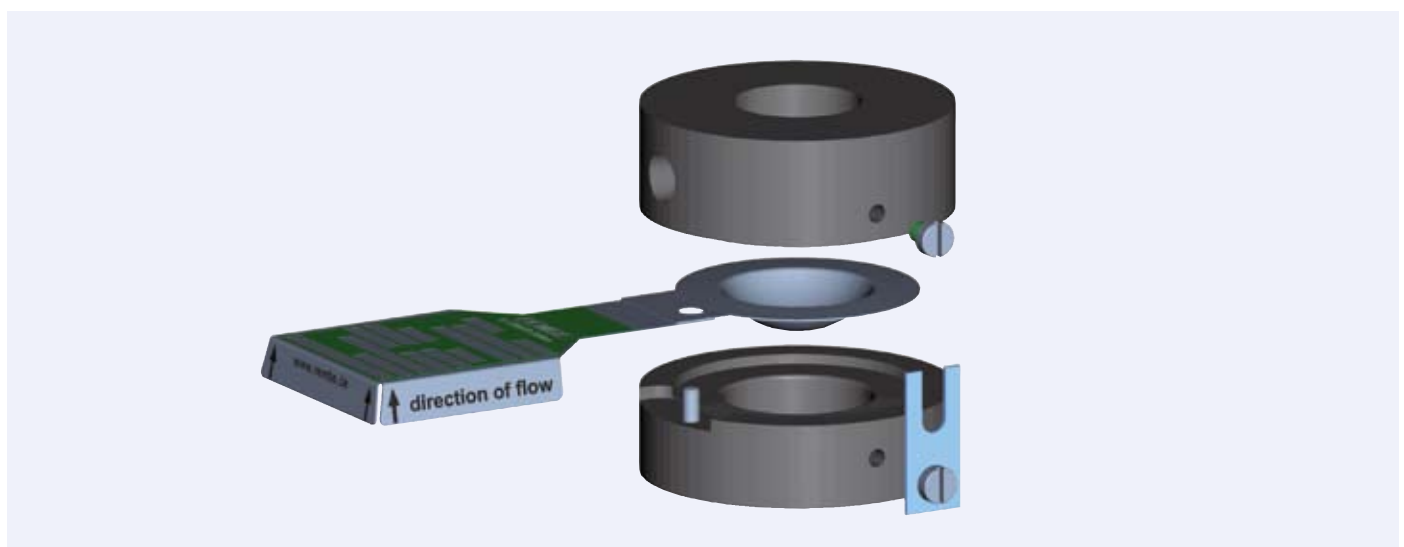

Materials and pressure ranges for the BT-KUB bursting disc

Depending on the aggressiveness of the medium, various material combinations are possible. The bursting pressure depends on the bursting temperature and the nominal diameter. Here is a list of possible examples of material combinations.

Metric units																				
Material	Standard		Special material																	
Bursting element	1.4404 / 316L		Nickel		Inconel®		Monel®		1.4404 / 316L		Hastelloy®		1.4404 / 316L		Titanium		1.4404 / 316L		Tantalum	
Sealing membrane	1.4401/316		Nickel		Inconel®		Monel®		Hastelloy®		Hastelloy®		Titanium		Titanium		Tantalum		Tantalum	
Medium temperature ¹⁾	min.	max.	min.	max.	min.	max.	min.	max.	min.	max.	min.	max.	min.	max.	min.	max.	min.	max.	min.	max.
	°C	-30	320	-30	420	-30	550	-30	400	-30	320	-30	420	-30	150	-30	150	-30	230	-30
Nominal diameter																				
Set pressures at 22 °C medium temperature [bar] ²⁾																				
DN	min.	max.	min.	max.	min.	max.	min.	max.	min.	max.	min.	max.	min.	max.	min.	max.	min.	max.	min.	max.
25	3,0	120,0	2,0	120,0	5,0	120,0	2,0	120,0	10,0	120,0	5,0	120,0	6,0	120,0	6,0	120,0	6,0	120,0	6,0	120,0
40	2,0	100,0	2,0	100,0	4,5	100,0	2,0	100,0	8,0	100,0	4,5	100,0	6,0	100,0	6,0	100,0	6,0	100,0	6,0	100,0
50	2,0	90,0	1,8	90,0	3,0	90,0	1,8	90,0	5,0	90,0	3,0	90,0	5,0	90,0	5,0	90,0	5,0	90,0	5,0	90,0
65	2,0	70,0	1,8	70,0	3,0	70,0	1,8	70,0	5,0	70,0	3,0	70,0	5,0	70,0	5,0	70,0	5,0	70,0	5,0	70,0
80	1,5	70,0	1,0	70,0	2,0	70,0	1,0	70,0	4,0	70,0	2,0	70,0	4,0	70,0	4,0	70,0	4,0	70,0	4,0	70,0
100	0,6	50,0	0,5	50,0	2,0	50,0	0,5	50,0	2,0	50,0	2,0	50,0	2,0	50,0	2,0	50,0	2,0	50,0	2,0	50,0
150	0,5	30,0	0,4	30,0	0,7	30,0	0,4	30,0	2,0	30,0	0,7	30,0	0,8	30,0	0,8	30,0	0,8	30,0	0,8	30,0

US units																				
Material	Standard		Special material																	
Bursting element	1.4404 / 316L		Nickel		Inconel®		Monel®		1.4404 / 316L		Hastelloy®		1.4404 / 316L		Titanium		1.4404 / 316L		Tantalum	
Sealing membrane	1.4401/316		Nickel		Inconel®		Monel®		Hastelloy®		Hastelloy®		Titanium		Titanium		Tantalum		Tantalum	
Medium temperature ¹⁾	min.	max.	min.	max.	min.	max.	min.	max.	min.	max.	min.	max.	min.	max.	min.	max.	min.	max.	min.	max.
	°F	-22	608	-22	788	-22	1022	-22	752	-22	608	-22	788	-22	302	-22	302	-22	446	-22
Nominal diameter																				
Set pressures at 72 °F medium temperature [bar] ²⁾																				
Valve size	min.	max.	min.	max.	min.	max.	min.	max.	min.	max.	min.	max.	min.	max.	min.	max.	min.	max.	min.	max.
1"	43,5	1740,0	29,0	1740,0	72,5	1740,0	29,0	1740,0	145,0	1740,0	72,5	1740,0	87,0	1740,0	87,0	1740,0	87,0	1740,0	87,0	1740,0
1 1/2"	29,0	1450,0	29,0	1450,0	65,3	1450,0	29,0	1450,0	116,0	1450,0	65,3	1450,0	87,0	1450,0	87,0	1450,0	87,0	1450,0	87,0	1450,0
2"	29,0	1305,0	26,1	1305,0	43,5	1305,0	26,1	1305,0	72,5	1305,0	43,5	1305,0	72,5	1305,0	72,5	1305,0	72,5	1305,0	72,5	1305,0
2 1/2"	29,0	1015,0	26,1	1015,0	43,5	1015,0	26,1	1015,0	72,5	1015,0	43,5	1015,0	72,5	1015,0	72,5	1015,0	72,5	1015,0	72,5	1015,0
3"	21,8	1015,0	14,5	1015,0	29,0	1015,0	14,5	1015,0	58,0	1015,0	29,0	1015,0	58,0	1015,0	58,0	1015,0	58,0	1015,0	58,0	1015,0
4"	8,7	725,0	7,3	725,0	29,0	725,0	7,3	725,0	29,0	725,0	29,0	725,0	29,0	725,0	29,0	725,0	29,0	725,0	29,0	725,0
6"	7,3	435,0	5,8	435,0	10,2	435,0	5,8	435,0	29,0	435,0	10,2	435,0	11,6	435,0	11,6	435,0	11,6	435,0	11,6	435,0

¹⁾ Temperatures below -30 °C / -22 °F upon request
²⁾ Set pressures for other temperatures upon request

Bursting pressure alterations in connection with the temperature

For the selection of bursting safety devices, special attention must be given to the effects of temperature. The respective bursting pressure is generally defined at a temperature of approx. 20 °C. If necessary, the bursting pressure levels will be specified in test certificates for both operation and room temperature.

The illustration shows the change in bursting pressure of the bursting disc composed of various materials in connection with the disc temperature.

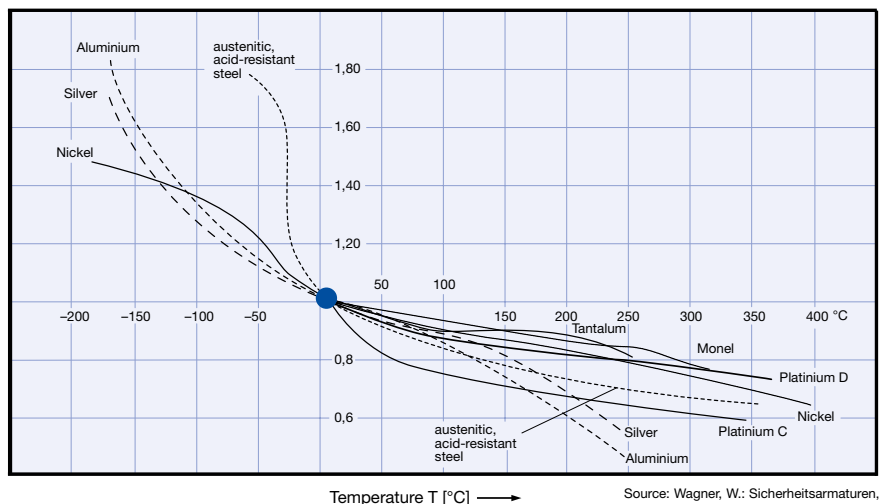

The bursting disc is downstream of the safety valve.

For applications in which the bursting disc is downstream of the safety valve, signal bursting discs are used. A signal bursting disc serves to display the system state locally, for example, in the control room. The initialisation of the signal is caused by the rupture of the bursting element (signalisation wire). The signalisation also continues after normalisation of pressure in the system lines, as a continuous display is activated for non-reversible bursting.

The safety valve-bursting disc combination at the outlet is offered by LESER as a special solution.

Installation

The signal bursting disc is mounted on the outlet side of the safety valve directly between the flange and the outlet line of the safety valve and designed for a low overpressure of max. 1 bar. In this regard, it must be ensured that back pressure cannot result in the premature rupture of the signal bursting disc, which would cause an incorrect display.

Design and material

The signal bursting disc consists of the following main components:

- two sealing membranes
- two sealing rings
- one signal element

The sealing rings must be selected with regard to their suitability for clamping the signal bursting disc between the respective flanges.

The sealing membrane is designed in standard stainless steel, because no special specifications to the material quality are required here.

Regulatory requirements of the downstream bursting disc

1. The bursting pressure of the bursting disc on the outlet side of a safety valve must be significantly lower than the set pressure of the safety valve. It must be selected with regard to the fact that the opening characteristic of the safety valve may not be disturbed by the build-up of back pressure between the safety valve and the bursting safety device (by leakage or with the start of discharge).
2. In the discharge line, the flow loss may not exceed the manufacturer's listed permissible back pressure level for the safety valve.



How to order – safety valves and bursting discs in combination Order example and order codes

1

Selection of safety valves

2

Selection Type 316 IG-KUB two-piece holder

4412.4542 5 bar H45 J22 H01 2.0

3162.9223

Y02

402

Please select your LESER Safety Valve.
Please use the "How to order" section of the corresponding product catalogue:

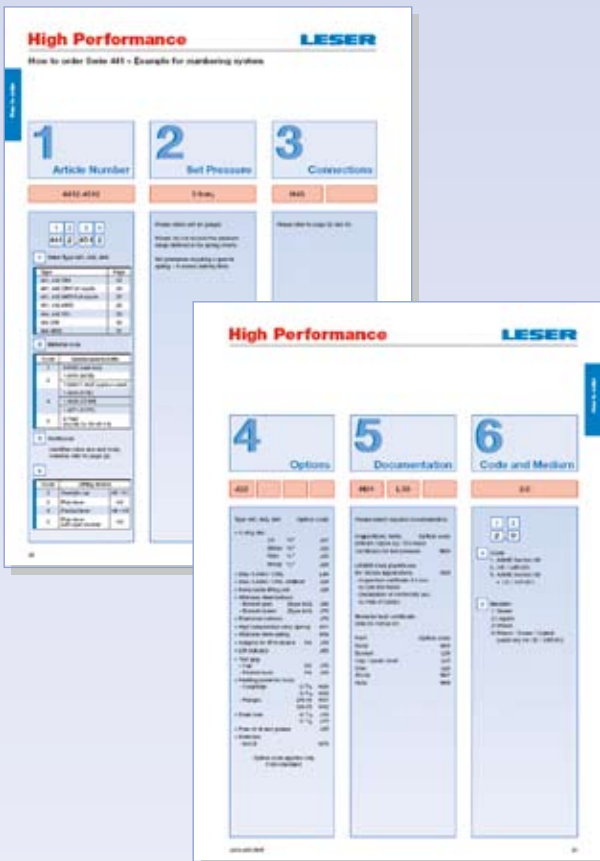

1 Article number

Please select an article number of the design S - safety valve with semi nozzle or design HS - safety valve with full nozzle.

2 Flange pressure ratings

Flange pressure rating	Option code
PN 16	Y13
PN 25	Y01
PN 40	Standard
PN 63	Y03
PN 100	Y04
CL150	Y14
CL300	Y16
CL600	Y42
CL900	Y43

3 Flange facings

Please select a corresponding DIN or ASME flange facing from the table on page 02/03.

4 Materials

Materials at the inlet	Option code
1.4571 / 316Ti	Standard
1.4404 / 316L	202
Hastelloy C4	203
571 / 316Ti Tantalum coating	204
Materials at the outlet	
1.4571 / 316Ti	Standard
1.4404 / 316L	302
Thread for Space monitoring device	
G ¹ / ₄	Standard
G ¹ / ₂	402
NPT 1/4"	403
NPT 1/2"	404

3

Selection BT-KUB bursting disc

3174.9243

12°C

20 bar

Y60

204

1 Article number

Please select your appropriate bursting disc.

2 Bursting temperature

3 Bursting pressure

Please enter the units (in gauge)!
The specified pressure ranges may not be exceeded.

4 Inspection Certificate

Inspection Certificate	Option code
TÜV certificate acc. to DIN EN 10204 3.2	Standard
Inspection certificate acc. to DIN EN 10204 3.1	Y51

5 Materials

Bursting element materials	Option code
1.4404 / 316L	Standard
1.4401 / 316	202
1.4435 / 316L	203
Nickel	204
Inconel	205
Monel®	206
Hastelloy® C	207
Sealing membrane materials	
1.4401 / 316	Standard
1.4435 / 316L	303
Nickel	304
Inconel	305
Monel®	306
Hastelloy® C4	307

4

Selection Space monitoring device

3184.0001

Y93

Y57

25 bar

1 Article number

2 Space monitoring device

Space monitoring device	Option code
Standard	Y93
Maximum pointer and contact gauge < DN 200 / 8"	Y94
Maximum pointer and contact gauge ≥ DN 200 / 8"	Y95

3 Pressure gauge

Pressure gauge	Option code
without pressure gauge	Y50
Standard	Y57
Maximum pointer	Y58
Contact gauge	Y59

4 Pressure range for pressure gauge

0 – 400 bar possible
Please enter the units (in gauge)!
The specified pressure ranges may not be exceeded.

Article numbers, flange pressure ratings and facings, materials

Type 316		IG-KUB two-piece holder							Manufacturer: REMBE® GmbH SAFETY+CONTROL	
		DN	25	40	50	65	80	100	150	
		Valve size	1"	1 1/2"	2"	2 1/2"	3"	4"	6"	
Article numbers										
Design S for safety valve with semi nozzle		3162.	9221	9222	9223	9224	9225	9226	9227	
Design HS for safety valve with full nozzle		3163.	9231	9232	9233	9234	9235	9236	9237	

As standard, incl. Certificate of Material Quality according to DIN EN 10204-3.1.

Nominal diameter > DN 150 / NPS 6"										
Please contact LESER for safety valves and bursting discs in combination in the nominal diameter > DN 150 / NPS 6" at sales@leser.com.										

Flange pressure ratings															
DN	25	40	50	65	80	100	150	DN	25	40	50	65	80	100	150
NPS	1"	1 1/2"	2"	2 1/2"	3"	4"	6"	NPS	1"	1 1/2"	2"	2 1/2"	3"	4"	6"
Option Code – Inlet two-piece holder								Option Code – Outlet two-piece holder							
PN 10	Y96	Y96	Y96	Y96	Y96	Y96	Y96	PN 10	Y97	Y97	Y97	Y97	Y97	Y97	Y97
PN 16	Y13	Y13	Y13	Y13	Y13	Y13	Y13	PN 16	Y23	Y23	Y23	Y23	Y23	Y23	Y23
PN 25	Y01	Y01	Y01	Y01	Y01	Y01	Y01	PN 25	Y05	Y05	Y05	Y05	Y05	Y05	Y05
PN 40	*	*	*	*	*	*	*	PN 40	*	*	*	*	*	*	*
PN 63	Y03	Y03	Y03	Y03	Y03	Y03	Y03	PN 63	Y07	Y07	Y07	Y07	Y07	Y07	Y07
PN 100	Y04	Y04	Y04	Y04	Y04	Y04	Y04	PN 100	Y08	Y08	Y08	Y08	Y08	Y08	Y08
CL150	Y14	Y14	Y14	Y14	Y14	Y14	Y14	CL150	Y24	Y24	Y24	Y24	Y24	Y24	Y24
CL300	Y16	Y16	Y16	Y16	Y16	Y16	Y16	CL300	Y26	Y26	Y26	Y26	Y26	Y26	Y26
CL600	Y42	Y42	Y42	Y42	Y42	Y42	Y42	CL600	Y44	Y44	Y44	Y44	Y44	Y44	Y44
CL900	Y43	Y43	Y43	Y43	Y43	Y43	Y43	CL900	Y45	Y45	Y45	Y45	Y45	Y45	Y45

Flange facings													
DIN EN 1092													
(also see LWN 313.40)													
								Inlet		Outlet			
								Option Code		Option Code			
Sealing strip								Form A		Y61		Y62	
								Form B1		*		*	
								Form B2		Y09		Y21	
Tongue, Form C								Y10		Y10		Y22	
Groove, Form D								Y11		Y11		Y25	
Male, Form E								Y12		Y12		Y28	
Female, Form F								Y15		Y15		Y29	
O-ring Male, Form G								Y18		Y18		Y30	
O-ring Female, Form H								Y19		Y19		Y37	
ASME B16.5													
								Inlet		Outlet			
								Option Code		Option Code			
Flat Face, FF								Y81		Y81		Y82	
Raised Face, RF								Y83		Y83		Y84	
Ring Joint Face, RTJ								Y85		Y85		Y86	
Small Tongue Face, STF								Y65		Y65		Y73	
Small Groove Face, SGF								Y66		Y66		Y74	
Long Tongue Face, LTF								Y67		Y67		Y75	
Long Groove Face, LGF								Y68		Y68		Y76	
Small Male Face, SMF								Y69		Y69		Y77	
Small Female Face, SFF								Y70		Y70		Y78	
Long Male Face, LMF								Y71		Y71		Y79	
Long Female Face, LFF								Y72		Y72		Y80	

Materials					
Inlet	Material	1.4571 / 316Ti	1.4404 / 316L	Hastelloy® C4	1.4571 / 316Ti Tantal coating
	Option Code	*	202	203	204
Outlet	Materials	1.4571 / 316Ti	1.4404 / 316L		
	Option Code	*	302		
Thread					
Thread for Space monitoring device	Material	G ¹ / ₄	G ¹ / ₂	NPT ¹ / ₄ "	NPT ¹ / ₂ "
	Option Code	*	402	403	404

Article numbers and certificates, materials and tolerances

Type 3174	BT-KUB bursting disc								Manufacturer: REMBE® GmbH SAFETY+CONTROL
	DN	25	40	50	65	80	100	150	
	Valve size	1"	1½"	2"	2½"	3"	4"	6"	
Article number									
	3174.	9241	9242	9243	9244	9245	9246	9247	

Certificates	
Standard	TÜV Certificate (DIN EN 10204 3.2) according to AD 2000-Merkblatt A1
Y51	Inspection Certificate (DIN EN 10204 3.1) according to AD 2000-Merkblatt A1

The bursting disc temperature in standard surrounding temperature is (15°C - 25°C).
For changing temperatures, please also specify your bursting disc temperature.

Materials								
Bursting element	Material	1.4404 / 316L	1.4401 / 316	1.4435 / 316L	Nickel	Inconel	Monel®	Hastelloy® C
	Option Code	*	202	203	204	205	206	207
Sealing membrane	Material		1.4404 / 316L	1.4435 / 316L	Nickel	Inconel	Monel®	Hastelloy® C
	Option Code		*	303	304	305	306	307

Bursting tolerances		
	lower tolerance level [%]	upper tolerance level [%]
Standard tolerance	-0	+10
Adapted tolerance range	-5	+5
Reduced tolerance in connection with an application case is possible	-2	+2

Please include the required tolerance in your order.

Purchased quantity
BT-KUB bursting discs are produced individually for every bursting pressure and tested (per charge, at least 2 bursting discs are tested to the point of destruction). This results in declining prices for higher purchase quantities. LESER therefore recommends having several bursting discs in storage. The BT-KUB bursting discs are offered in 3 quantity groups. Please consult the current LESER price list to take full advantage of the price scale.

Article number and pressure gauge selection

Type 3184		Space monitoring device				
Article number		3184.0001				
Valve size		< DN 200 / 8"			≥ DN 200 / 8"	
Option Code	Standard	Maximum pointer and contact gauge		Maximum pointer and contact gauge		
Connection	Y93	Y94		Y95		
Connection to the IG-KUB two-piece holder	G ¹ / ₄	G ¹ / ₄		G ¹ / ₄		
Pressure gauge connection	G ¹ / ₄	G ¹ / ₂		G ¹ / ₂		
Connection for excess overflow valve	G ¹ / ₈	G ¹ / ₈		G ¹ / ₈		
Pressure gauge	Standard	Contact gauge	Maximum pointer	Contact gauge	Maximum pointer	
Option Code	Y57	Y58	Y59	Y58	Y59	
Pressure range in bar						
0 – 1,6	x	x	x	x	x	
0 – 2,5		x	x	x	x	
0 – 6	x	x	x	x	x	
0 – 10		x	x	x	x	
0 – 16		x	x	x	x	
0 – 25	x	x	x	x	x	
0 – 40		x	x	x	x	
0 – 60		x	x	x	x	
0 – 100	x	x	x	x	x	
0 – 160		x	x	x	x	
0 – 250		x	x	x	x	
0 – 400	x	x	x	x	x	

For space monitoring device without a pressure gauge, please select Option code Y50.

Dimensions

Metric units

		DN	25	40	50	65	80	100	150	
		Valve size	1"	1 1/2"	2"	2 1/2"	3"	4"	6"	
Pressure rating										
High IG-KUB two-piece holder Design S	k	[mm]	46,0	46,0	53,0	57,0	60,0	68,0	80,0	
High IG-KUB two-piece holder Design HS	k	[mm]	49,0	59,0	79,0	100,0	114,0	147,0	210,0	
Diameter IG-KUB two-piece holder	Ød	[mm] PN 10 – PN 16	71,0	92,0	105,0	127,0	142,0	162,0	217,0	
		[mm] PN 25 – PN 40	71,0	92,0	105,0	127,0	142,0	167,0	223,0	
		[mm] PN 64	82,0	103,0	113,0	144,0	146,0	171,0	245,0	
		[mm] PN 100 / PN 160	82,0	103,0	119,0	144,0	154,0	177,0	255,0	
Length of space monitoring device	L _Z	[mm]	145,5							
Length Space monitoring device to centre line	L _A	[mm] PN 10 – PN 16	181,0	191,5	198,0	209,0	216,5	226,5	254,0	
		[mm] PN 25 – PN 40	181,0	191,5	198,0	209,0	216,5	229,0	257,0	
		[mm] PN 64	186,5	197,0	202,0	217,5	218,5	231,0	268,0	
		[mm] PN 100 / PN 160	186,5	197,0	205,0	217,5	222,5	234,0	273,0	

US units

		DN	25	40	50	65	80	100	150	
		Valve size	1"	1 1/2"	2"	2 1/2"	3"	4"	6"	
Pressure rating										
High IG-KUB two-piece holder Design S	k	[inch]	1 13/16	1 13/16	2 3/32	2 1/4	2 3/8	2 11/16	3 5/32	
High IG-KUB two-piece holder Design HS	k	[inch]	1 15/16	2 5/16	3 1/8	3 15/16	4 1/2	5 25/32	8 9/32	
Diameter IG-KUB two-piece holder	Ød	[inch] CL150	2 15/32	3 7/32	3 31/32	4 23/32	5 1/4	6 23/32	8 5/8	
		[inch] CL300	2 23/32	3 5/8	4 1/8	5	5 3/4	6 31/32	9 23/32	
		[inch] CL600	2 23/32	3 5/8	4 1/8	5	5 3/4	7 15/32	10 11/32	
		[inch] CL900	3	3 3/4	5 15/32	6 3/8	6 1/2	8	11 7/32	
[inch] CL1500	3	3 3/4	5 15/32	6 3/8	6 23/32	8	10 15/16			
Length of space monitoring device	L _Z	[inch]	5 23/32							
Length Space monitoring device to centre line	L _A	[inch] CL150	6 31/32	7 11/32	7 23/32	8 3/32	8 11/32	9 3/32	10 1/32	
		[inch] CL300	7 3/32	7 17/32	7 25/32	8 7/32	8 19/32	9 7/32	10 19/32	
		[inch] CL600	7 3/32	7 17/32	7 25/32	8 7/32	8 19/32	9 15/32	10 29/32	
		[inch] CL900	7 7/32	7 19/32	8 15/32	8 29/32	8 31/32	9 23/32	11 11/32	
[inch] CL1500	7 7/32	7 19/32	8 15/32	8 29/32	9 3/32	9 23/32	11 3/16			

Please find the safety valve-specific dimensions in the appropriate product catalogue or contact sales@leser.com.

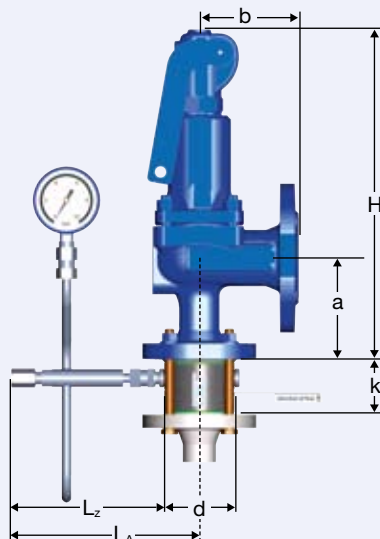

Bursting disc catalog
Edition July 2009

LWN 487.21-E / 0777.5657 / 3000

LESER

The-Safety-Valve.com

LESER GmbH & Co. KG

20537 Hamburg, Wendenstr. 133-135
20506 Hamburg, P.O. Box 26 16 51

Fon +49 (40) 251 65-100
Fax +49 (40) 251 65-500

E-Mail: sales@leser.com
www.leser.com